

ANSI/IEEE Std 421.1-1986

(Revision of IEEE Std 421-1972)

An American National Standard

IEEE Standard Definitions for Excitation Systems for Synchronous Machines

Sponsor

**Power Generation Committee
of the
IEEE Power Engineering Society**

Approved June 13, 1985

IEEE Standards Board

Approved November 21, 1985

American National Standards Institute

© Copyright 1986 by

The Institute of Electrical and Electronics Engineers, Inc 345 East 47th Street, New York, NY 10017, USA

No part of this publication may be reproduced in any form, in an electronic retrieval system or otherwise, without the prior written permission of the publisher.

IEEE Standards documents are developed within the Technical Committees of the IEEE Societies and the Standards Coordinating Committees of the IEEE Standards Board. Members of the committees serve voluntarily and without compensation. They are not necessarily members of the Institute. The standards developed within IEEE represent a consensus of the broad expertise on the subject within the Institute as well as those activities outside of IEEE which have expressed an interest in participating in the development of the standard.

Use of an IEEE Standard is wholly voluntary. The existence of an IEEE Standard does not imply that there are no other ways to produce, test, measure, purchase, market, or provide other goods and services related to the scope of the IEEE Standard. Furthermore, the viewpoint expressed at the time a standard is approved and issued is subject to change brought about through developments in the state of the art and comments received from users of the standard. Every IEEE Standard is subjected to review at least once every five years for revision or reaffirmation. When a document is more than five years old, and has not been reaffirmed, it is reasonable to conclude that its contents, although still of some value, do not wholly reflect the present state of the art. Users are cautioned to check to determine that they have the latest edition of any IEEE Standard.

Comments for revision of IEEE Standards are welcome from any interested party, regardless of membership affiliation with IEEE. Suggestions for changes in documents should be in the form of a proposed change of text, together with appropriate supporting comments.

Interpretations: Occasionally questions may arise regarding the meaning of portions of standards as they relate to specific applications. When the need for interpretations is brought to the attention of IEEE, the Institute will initiate action to prepare appropriate responses. Since IEEE Standards represent a consensus of all concerned interests, it is important to ensure that any interpretation has also received the concurrence of a balance of interests. For this reason IEEE and the members of its technical committees are not able to provide an instant response to interpretation requests except in those cases where the matter has previously received formal consideration.

Comments on standards and requests for interpretations should be addressed to:

Secretary, IEEE Standards Board
345 East 47th Street
New York, NY 10017
USA

Foreword

(This Foreword is not a part of ANSI/IEEE Std 421.1-1986, IEEE Standard Definitions for Excitation Systems for Synchronous Machines.)

This standard defines elements and commonly used components in excitation systems and contains definitions for excitation systems applied to synchronous machines, for general requirements of a synchronous machine refer to ANSI C50.10-1977.

A synchronous machine excitation control system operating under automatic control is a feedback control system. Thus, the working group Terminology of the Excitation Subcommittee of the Power Generation Committee adopted definitions that had common basis to excitation systems. Efforts were made not to conflict terms found in ANSI/IEEE Std 100-1984 , IEEE Standard Dictionary of Electrical and Electronics Terms, but to clarify or more fully define terms as related specifically to excitation of synchronous machines.

The task of the working group can be divided into two areas:

- 1) To gather all the existing definitions applicable to the field of excitation systems, and from these definitions to extract those definitions of value.
- 2) To formulate new definitions where these are needed.

Three definitions to classify exciters are now established:

- 1) dc generator — commutator exciter
- 2) alternator — rectifier exciter
- 3) static — rectifier exciter

It is thought that these types of exciters cover most if not all of the types used in modern excitation systems for large synchronous machines. The commutator exciter can have a continuous or noncontinuous acting regulator, and the rectifier exciter can have controlled or noncontrolled rectifiers.

This standard would also like to draw particular attention to three other recent excitation system documents:

- 1) ANSI/IEEE Std 421A-1978 ¹. This guide presents dynamic performance criteria, definitions and test procedures for excitation control systems as applied by electric utilities.
- 2) ANSI/IEEE Std 421B-1979 ¹. This standard applies to high-potential testing of complete excitation systems and their components for synchronous machines.
- 3) IEEE Committee Report, Excitation System Models for Power System Stability Studies. This paper presents excitation system models suitable for use in large-scale system stability studies. With these models, most of the excitation systems currently in widespread use on large, system-connected generators in North America can be represented. This paper replaces a similar committee report dated 1968.

IEEE Std 421-1972 was a definitions standard that is referenced in many other IEEE standards, papers, committee reports, etcetera. The changes being made in this revision do not invalidate any standard, paper, report, etcetera, that used IEEE Std 421-1972 as a reference document.

Previous definitions which included a phrase *response ratio* have been deleted. Only a single definition, excitation system nominal response, encompassing the overall performance of the excitation system is presented. Unique conditions for various excitation systems as related to this performance parameter are identified.

¹When the documents ANSI/IEEE Std 421A-1978 and ANSI/IEEE Std 421B-1979 are superseded by a revision, the revisions will be redesignated as ANSI/IEEE Std 421.2 and ANSI/IEEE Std 421.3 , respectively.

This revision has deleted a few basic terms, such as amplifier, drift, error, and input signal. These terms are taken care of in the IEEE Standard Dictionary. A few additional terms have been added. Table 1 of this revision shows a detailed correlation between the various excitation systems and the appropriate computer model type as described in the IEEE committee report on computer modeling of excitation systems.

Members of the Working Group of the Excitation Systems Subcommittee of the Power Generation Committee of the IEEE Power Engineering Society, which formulated the 1972 standard, were as follows:

P. O. Bobo, *Chair*

R. R. Bast	F. W. Keay	Michael Temoshok
M. L. Crenshaw	F. R. Schleif	R. H. Waltman
A. C. Dolbec	J. W. Skooglund	H. S. Wilson
K. R. McClymont	G. I. Stillman	

Others contributing to the work of the group were:

J. R. Mather	P. R. Landrieu	A. S. Rubenstein
--------------	----------------	------------------

Members of the Working Group of the Excitation Systems Subcommittee of the Power Generation Committee of the IEEE Power Engineering Society, which revised this standard, are:

J. R. Michalec, *Chair*

M. L. Crenshaw	D. C. Lee	D. G. Ramey
K. J. Dhir	J. R. Mather	J. W. Thomas
D. I. Gorden	G. R. Meloy	I. Trebincevic
H. Jaleeli	D. H. Miller	R. H. Waltman
F. W. Keay	J. O. Nichols	T. R. Whittemore

The following persons were on the balloting committee that approved this document for submission to the IEEE Standards Board:

W. W. Avril	D. I. Gorden	D. E. Roberts
M. S. Baldwin	R. D. Handel	W. J. Rom
G. G. Boyle	M. E. Jackowski	M. N. Sprouse
F. L. Brennan	P. R. Landrieu	A. J. Spurgin
P. G. Brown	G. Luri	J. E. Stoner, Jr
H. E. Church, Jr	O. S. Mazzoni	J. B. Sullivan
R. S. Coleman	M. W. Migliaro	S. Tjepkema
E. A. Cooper	J. L. Mills	R. H. Waltman
R. E. Cotta	P. A. Nevins	T. Whittemore
M. L. Crenshaw	S. Nikolakakos	C. J. Wylie
P. M. Davidson	J. T. Nikolas	T. D. Youkins
G. R. Engmann	M. I. Olken	D. Diamant
W. M. Fenner	R. J. Reiman	G. Berman
A. H. Ferber		A. H. Foss

When the IEEE Standards Board approved this standard on June 13, 1985, it had the following membership:

John E. May, *Chair*
John P. Riganati, *Vice Chair*
Sava I. Sherr, *Secretary*

James H. Beall
Fletcher J. Buckley
Rene Castenschiold
Edward Chelotti
Edward J. Cohen
Paul G. Cummings
Donald C. Fleckenstein
Jay Forster

Daniel L. Goldberg
Kenneth D. Hendrix
Irvin N. Howell
Jack Kinn
Joseph L. Koepfinger*
Irving Kolodny
R. F. Lawrence
Lawrence V. McCall

Donald T. Michael*
Frank L. Rose
Clifford O. Swanson
J. Richard Weger
W. B. Wilkens
Charles J. Wylie

*Member emeritus

CLAUSE	PAGE
1. Scope	1
2. Excitation System Definitions	1
3. References	6
4. Typical Elements and Components of Excitation Control Systems	6
5. Bibliography.....	16

An American National Standard

IEEE Standard Definitions for Excitation Systems for Synchronous Machines

1. Scope

This standard defines elements and commonly used components in excitation control systems and contains definitions for excitation systems as applied to synchronous machines. The primary purpose is to provide a vocabulary for

- 1) Writing excitation systems specifications
- 2) Evaluating excitation system performance
- 3) Specifying methods for excitation system tests
- 4) Preparing excitation system standards
- 5) Serving as an educational means for those becoming acquainted with excitation systems

2. Excitation System Definitions

accuracy: The degree of correspondence between the controlled variable and the desired value under specified conditions such as load changes, ambient temperature, humidity, frequency, and supply voltage variations. Quantitatively, it is expressed as the ratio of difference between the controlled variable and the desired value to the desired value.

air gap field voltage: The synchronous machine field voltage required to produce rated voltage on the air-gap line of the synchronous machine with its field winding at (1) 75 °C for field windings designed to operate at rating with a temperature rise of 60 °C or less; or (2) 100 °C for field windings designed to operate at rating with a temperature rise greater than 60 °C. *Note.* This defines one per unit excitation system voltage for use in computer representation of excitation systems.

air-gap line: The extended straight line part of the no-load saturation curve of the synchronous machine.

alternator-rectifier exciter: An exciter whose energy is derived from an alternator and converted to direct current by rectifiers. The exciter includes an alternator and power rectifiers which may be either noncontrolled or controlled, including gate circuitry. It is exclusive of input control elements. The alternator may be driven by a motor, prime mover, or by the shaft of the synchronous machine. The rectifiers may be stationary or rotating with the alternator shaft.

automatic control: In excitation control system usage, automatic control refers to maintaining synchronous machine terminal voltage without operator action, over the operating range of the synchronous machine within its capabilities. *Note:* Voltage regulation under automatic control may be modified by the action of reactive or active load compensators or by var control elements; or may be constrained by the action of various limiters included in the excitation system.

band of regulated voltage: The band or zone, expressed in percent of the rated value of the regulated voltage, within which the excitation system will hold the regulated voltage of an electric machine during steady or gradually changing conditions over a specified range of load.

brushless exciter: An alternator-rectifier exciter employing rotating rectifiers with a direct connection to the synchronous machine field thus eliminating the need for field brushes, see Fig 7.

ceiling current: The maximum direct current which the excitation system is able to supply from its terminals for a specified time.

ceiling voltage: The maximum direct voltage which the excitation system is able to supply from its terminals under defined conditions. *Notes:* (1) The no-load ceiling voltage is determined with the excitation system supplying no current. (2) The ceiling voltage under load is determined with the excitation system supplying ceiling current. (3) For excitation system whose supply depends on the synchronous machine voltage and (if applicable) current, the nature of power system disturbance and specific design parameters of the excitation system and the synchronous machine influence the excitation system output. For such systems, the ceiling voltage is determined considering an appropriate voltage drop and (if applicable) current increase. (4) For excitation systems employing a rotating exciter, the ceiling voltage is determined at rated speed.

compound source-rectifier exciter: An exciter whose energy is derived from the currents and potentials of the ac terminals of the synchronous machine and converted to direct current by rectifiers. The exciter includes the power transformers (current and potential), reactors, and rectifiers which may be either noncontrolled or controlled, including gate circuitry. It is exclusive of input control elements.

continuously acting regulator: A regulator that initiates a corrective action for a sustained infinitesimal change in the controlled variable.

current compensator: An element of the excitation system that acts to compensate for synchronous machine load current effects. *Notes:* (1) Examples are reactive current compensator and active current compensator. A reactive current compensator is a compensator that acts to modify the regulated voltage in accordance with reactive current. An active current compensator is a compensator that acts to modify the regulated voltage in accordance with active current. (2) Historically, terms such as equalizing reactor and cross current compensator have been used to describe the function of a reactive compensator. These terms are deprecated. (3) Reactive compensators are generally applied with synchronous machine voltage regulators to obtain reactive current sharing among synchronous machines operating in parallel. They function in the following two ways: (a) Reactive droop compensation is the more common method. It creates a droop in synchronous machine terminal voltage proportional to reactive current and equivalent to that which would be produced by the insertion of a reactor between the synchronous machine terminals and the paralleling point. (b) Reactive differential compensation is used where droop in synchronous machine voltage is not wanted. It is obtained by a series differential connection of the various synchronous machine, current transformer secondaries, and reactive compensators. The difference current for any synchronous machine from the common series current creates a compensating voltage in the input to the particular synchronous machine voltage regulator which acts to modify the synchronous machine excitation to reduce to minimum (zero) its differential reactive current. (4) Line drop compensators modify synchronous machine terminal voltage by regulator action to compensate for the impedance drop from the machine terminals to a fixed point in the external circuit. Action is accomplished by insertion within the regulator input circuit, a voltage equivalent to the impedance drop. The voltage drops of the resistance and reactance portions of the impedance are obtained, respectively, by an active compensator and a reactive compensator.

dc generator-commutator exciter: An exciter whose energy is derived from a dc generator. The exciter includes a dc generator with its commutator and brushes. It is exclusive of input control elements. The exciter may be driven by a motor, prime mover, or by the shaft of the synchronous machine.

de-excitation: The removal of the excitation of a synchronous machine, main exciter, or pilot exciter. *Note.* De-excitation may be accomplished by various means, such as a dc field breaker, ac supply breaker, static switches, phase-back control of controlled rectifiers, or a combination of these.

discharge resistor: A resistor that, upon interruption of excitation source current, is connected across the field windings of a synchronous machine or an exciter to limit the transient voltage in the field circuit and to hasten the decay of field current of the machine.

error signal: In a control system the error signal is the difference between a sensing signal and a constant reference signal. *Note:* In excitation control systems sensing signals may be proportional to synchronous machine terminal voltage, the ratio of terminal voltage to frequency, active or reactive armature current, active or reactive power, power factor, terminal frequency, shaft speed, generator field voltage or field current, and exciter field voltage or field current.

excitation power current transformer: The elements in a compound source-rectifier excitation system which transfer electrical energy from the synchronous machine armature current to the excitation system at a magnitude and phase relationship required by the excitation system.

excitation power potential transformer: The element or elements in a compound source-rectifier excitation system which transfer electrical energy from the synchronous machine armature terminals to the excitation system at a magnitude and phase relationship required in the excitation system. Also, the element or elements in a potential source-rectifier excitation system which transfer electrical energy either from the machine terminals or from an auxiliary bus to the excitation system at a magnitude level required by the excitation system.

excitation system: The equipment providing field current for a synchronous machine, including all power, regulating, control, and protective elements.

excitation system duty cycle: An initial operating condition and a subsequent sequence of events of specified duration to which the excitation system will be exposed. *Note:* The duty cycle usually involves a three-phase fault of specified duration which is located electrically close to the synchronous machine. Its primary purpose is to specify the duty that the excitation system components can withstand without incurring maloperation or damage.

excitation system nominal response: The rate of increase of the excitation system output voltage determined from the excitation system voltage response curve, divided by the rated field voltage. This rate, if maintained constant, would develop the same voltage-time area as obtained from the actual curve over the first half-second interval (unless a different time interval is specified). Refer to Fig 1. *Notes:* (1) The excitation system nominal response shall be determined with the excitation system voltage initially equal to the rated field voltage of the synchronous machine, after which the excitation system ceiling voltage is rapidly attained by introducing a specified voltage error step. (2) The excitation system nominal response shall be determined with the excitation system loaded with a resistance equal to the field resistance under rated load conditions and adequate inductance so that voltage drop effects and current and voltage waveforms are reasonably duplicated. (3) For excitation systems whose supply depends on the synchronous machine voltage and (if applicable) current, the nature of the power system disturbance and specific design parameters of the excitation system and the synchronous machine influence the excitation system output. For such systems, the excitation system nominal response shall be determined considering an appropriate voltage drop and (if applicable) current increase. (4) If, for practical considerations, tests can only be made on individual components or the entire excitation system but only at partial or no-load, analytical methods may be used to predict performance under the loading conditions of Note 2. (5) For excitation systems employing a rotating exciter, the excitation system nominal response shall be determined at rated speed.

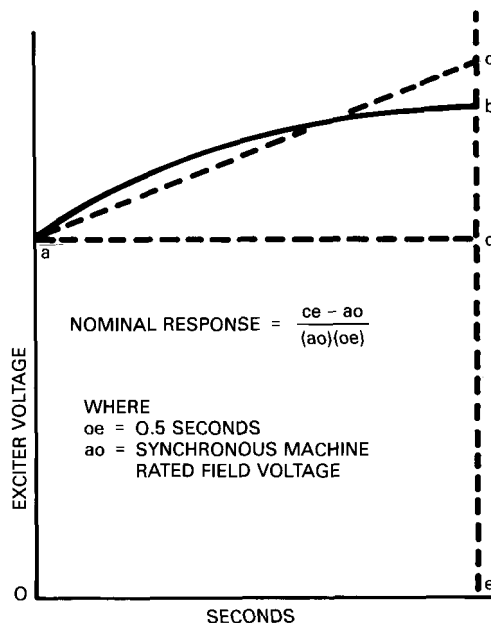

Figure 1—Excitation System Nominal Response

excitation system output terminals: The place of output from the equipment comprising the excitation system. These terminals may be identical with the field winding terminals.

excitation system rated current: The direct current at the excitation system output terminals which the excitation system can supply under defined conditions of its operation. This current is at least that value required by the synchronous machine under the most demanding continuous operating conditions (generally resulting from synchronous machine voltage frequency variations and power factor variations).

excitation system rated voltage: The direct voltage at the excitation system output terminals which the excitation system can provide when delivering excitation system rated current under rated continuous load conditions of the synchronous machine with its field winding at (1) 75 °C for field windings designed to operate at rating with a temperature rise of 60 °C or less; or (2) 100 °C for field windings designed to operate at rating with a temperature rise greater than 60 °C.

excitation system stabilizer: An element or group of elements that modify the forward signal by either series or feedback compensation to improve the dynamic performance of the excitation control system.

excitation system voltage response time: The time in seconds for the excitation voltage to attain 95% of the difference between ceiling voltage and rated load field voltage under specific conditions.

excitation system voltage time response: The excitation system output voltage expressed as a function of time, under specified conditions. *Note:* A similar definition can be applied to the excitation system major components, the exciter and regulator, separately.

exciter: The equipment providing the field current for the excitation of a synchronous machine.

field discharge circuit breaker: A circuit breaker having main contacts for energizing and deenergizing the field of a synchronous machine or rotating exciter and having discharge contacts for short-circuiting the field through the discharge resistor prior to the opening of the circuit breaker main contacts. The discharge contacts also disconnect the field from the discharge resistor following the closing of the main contacts. *Notes:* (1) When used in the main field of a synchronous machine the circuit breaker is designated as a main field discharge circuit breaker. (2) When used in the field circuit of a rotating exciter of the main machine, the circuit breaker is designated as an exciter field discharge circuit breaker.

field forcing: A control function that rapidly drives the field current of a synchronous machine in the positive or in the negative direction.

field winding: A winding on either the stationary or the rotating part of a synchronous machine whose sole purpose is the production of the main electromagnetic field of the machine.

field winding terminals: The place of input to the field winding of the synchronous machine. If there are brushes and sliprings these are considered to be part of the field winding.

high initial response: An excitation system capable of attaining 95% of the difference between ceiling voltage and rated-load field voltage in 0.1 s or less under specified conditions.

large signal performance: Response of an excitation control system, excitation system, or elements of an excitation system to signals which are large enough that nonlinearities must be included in the analysis of the response to obtain realistic results.

limiter: An element of the excitation system which acts to limit a variable by modifying or replacing the functions of the primary detector element when predetermined conditions have been reached. *Notes:* Examples: (1) An under excitation limiter prevents the voltage regulator from lowering the excitation of the synchronous machine below a prescribed level. (2) An over excitation limiter prevents the voltage regulator from raising the excitation of the synchronous machine above a level which would cause a thermal overload in the machine field; refer to ANSI C50.13-1977 [2].¹ (3) A volts per hertz limiter acts, through the voltage regulator to correct for a machine terminal voltage to frequency ratio that is considered abnormal. (4) Other types of limiters may be used to control various quantities, such as, rotor angle, excitation output, etcetera.

manual control: In excitation control system usage, manual control refers to maintaining synchronous machine terminal voltage by operator action. *Note:* Manual control means may include an exciter field rheostat, controlled rectifiers, or a dc regulator controlling either exciter field current or exciter output voltage, or other means that do not include regulation of synchronous machine terminal voltage.

no-load field current: The direct current in the field winding of synchronous machine required to produce rated voltage at no-load and rated speed.

no-load field voltage: The voltage required across the terminals of the field winding of the synchronous machine under conditions of no-load, rated speed, and rated terminal voltage, and with the field winding at 25 °C.

noncontinuously acting regulator: A regulator that requires a sustained finite change in the controlled variable to initiate corrective action.

pilot exciter: The equipment providing the field current for the excitation of another exciter.

potential source-rectifier exciter: An exciter whose energy is derived from a stationary ac potential source and converted to direct current by rectifiers. The exciter includes the power potential transformers and power rectifiers which may be either noncontrolled or controlled, including gate circuitry. It is exclusive of input control elements. The source of ac power may come from the machine terminals or from a station auxiliary bus or a separate winding within the synchronous machine.

power system stabilizer: An element or group of elements that provide an additional input to the regulator to improve power system performance. *Note:* A number of different quantities may be used as input to the power system stabilizer, such as, shaft speed, frequency, synchronous machine electrical power, etcetera.

rated field current: The direct current in the field winding of the synchronous machine when operating at rated voltage, current, power factor, and speed.

rated field voltage: The voltage required across the terminals of the field winding of the synchronous machine under rated continuous load conditions of the synchronous machine with its field winding at (1) 75 °C for field windings designed to operate at rating with a temperature rise of 60 °C or less; or (2) 100 °C for field windings designed to operate at rating with a temperature rise greater than 60 °C.

¹Numbers in brackets correspond to those of the references in Section 3. of this standard; when preceded by B, they correspond to the bibliography in Section 5 of this standard.

rotating amplifier: An electric machine in which a small energy change in the field is amplified to a large energy change at the armature terminals.

small signal performance: The response of an excitation control system, excitation system, or elements of an excitation system to signals which are small enough that nonlinearities can be disregarded in the analysis of the response, and operation can be considered to be linear.

synchronous machine regulator: A regulator that couples the output variables of the synchronous machine to the input of the exciter through feedback and forward controlling elements for the purpose of regulating the synchronous machine output variables.

voltage regulating adjuster: A device associated with a synchronous machine voltage regulator by which adjustment of the synchronous machine terminal voltage can be made.

voltage regulator: A synchronous machine regulator that functions to maintain the terminal voltage of a synchronous machine at a predetermined value, or to vary it according to a predetermined plan. *Note:* Historical term, included for reference only. The preferred term is synchronous machine regulator.

3. References

- [1] ANSI C50.10-1977, American National Standard General Requirements for Synchronous Machines.²
- [2] ANSI C50.13-1977, American National Standard Requirements for Combustion Gas Turbine Driven Cylindrical Rotor Synchronous Generators.
- [3] ANSI/IEEE Std 100-1984, IEEE Standard Dictionary of Electrical and Electronics Terms.³
- [4] ANSI/IEEE Std 421A-1978, IEEE Guide for Identification, Testing, and Evaluation of the Dynamic Performance of Excitation Control Systems.*
- [5] ANSI/IEEE Std 421B-1979 (R 1984), IEEE Standard for High-Potential-Test Requirements for Excitation Systems for Synchronous Machines.

4. Typical Elements and Components of Excitation Control Systems

The following figures are included only to aid in the understanding of the excitation control system.

Figure 2 is a generalized block diagram identifying excitation system control and protective elements. The symbols used in Fig 2 are taken directly from [B1] and are defined in Table 1.

Table 2 shows the correlation between the diagrams of this standard and the excitation model types used in [B1]. Table 2 also shows a further breakdown of the three basic exciter types as well as the source of exciter power.

Figures 3 through 14 (except for Fig 6) show typical configurations of the principal excitation systems currently being supplied. These single line diagrams identify the source of the excitation power with control circuits shown for clarity and general understanding.

Figure 15 represents the typical three phase rectifier bridge circuits that may be used in excitation control systems. The rectifier bridge circuit is shown in Figs 4 and 7 through 14 as a lone rectifier in a block. These rectifiers are the main source of the field current for an exciter or generator main field.

² ANSI documents are available from the Sales Department, American National Standards Institute, 1430 Broadway, New York, NY 10018.

³ When the documents ANSI/IEEE Std 421A-1978 and ANSI/IEEE Std 421B-1979 are superseded by a revision, the revisions will be redesignated as ANSI/IEEE Std 421.2 and ANSI/IEEE Std 421.3, respectively.

The potential source and compound source systems have *power* PT's and *power* CT's. These transformers supply power to the rectifier bridge circuits; they should not be confused with the instrument transformers supplying intelligence to the automatic control circuit.

Table 1—Nomenclature for Fig 2

E_{FD}	—	Exciter output voltage (generator field voltage)
I_{FD}	—	Exciter output current (generator field current)
V_{FE}	—	Signal proportional to exciter field current
V_L	—	Limiters and protective elements feedback
V_R	—	Regulator output
V_S	—	Power system stabilizer output
V_{SI}	—	Power system stabilizer inputs (shaft speed, frequency, synchronous machine electric power, and others)
V_T, I_T	—	Generator terminal voltage and current, respectively
f	—	Generator terminal frequency
V_{REF}	—	Voltage regulator reference voltage

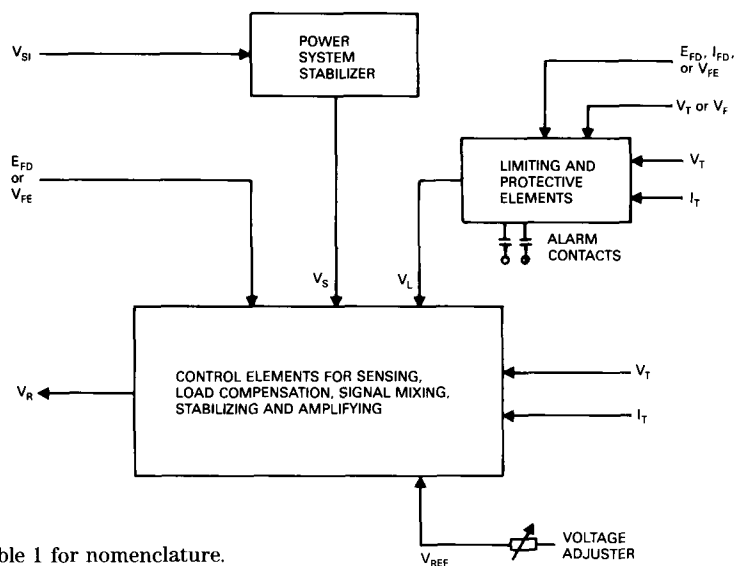

NOTE: See Table 1 for nomenclature.

Figure 2—Automatic Control Elements

Table 2—Excitation System Characteristics

Exciter Category	Type of Exciter	Exciter Power Source	Figure	High Initial Response	Computer Model Type*
dc	dc generator commutator exciter	motor-generator set or synchronous machine shaft	3, 5	no	dc1
			4	no	dc2
			6	no	dc3
ac	alternator-stationary noncontrolled rectifier	synchronous machine shaft	8	no	ac3
	alternator-rotating noncontrolled rectifier (brushless)	synchronous machine shaft	7	no yes	ac1 ac2
	alternator-stationary controlled rectifier	synchronous machine shaft	9	yes	ac4
st	potential source controlled rectifier	synchronous machine voltage or auxiliary bus voltage	10	yes	st1
			14	yes	st3
	compound source noncontrolled rectifier	synchronous machine voltage and current	11	no	st2
	compound source controlled rectifier	synchronous machine voltage and current	12, 13	yes	st3

*See [B1].

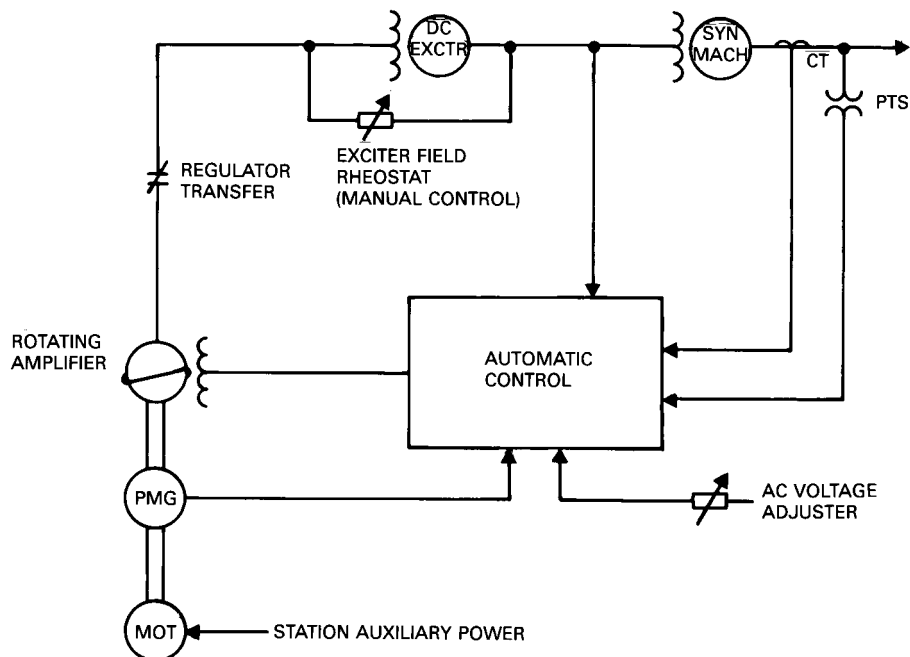

Figure 3—DC Generator-Commutator Exciter with Rotating Amplifier

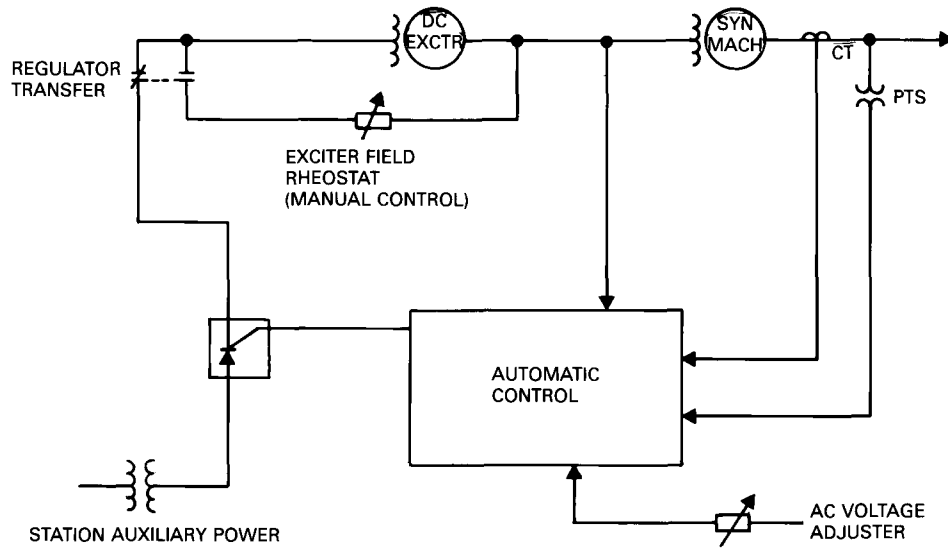

Figure 4—DC Generator-Commutator Exciter with Static Amplifier

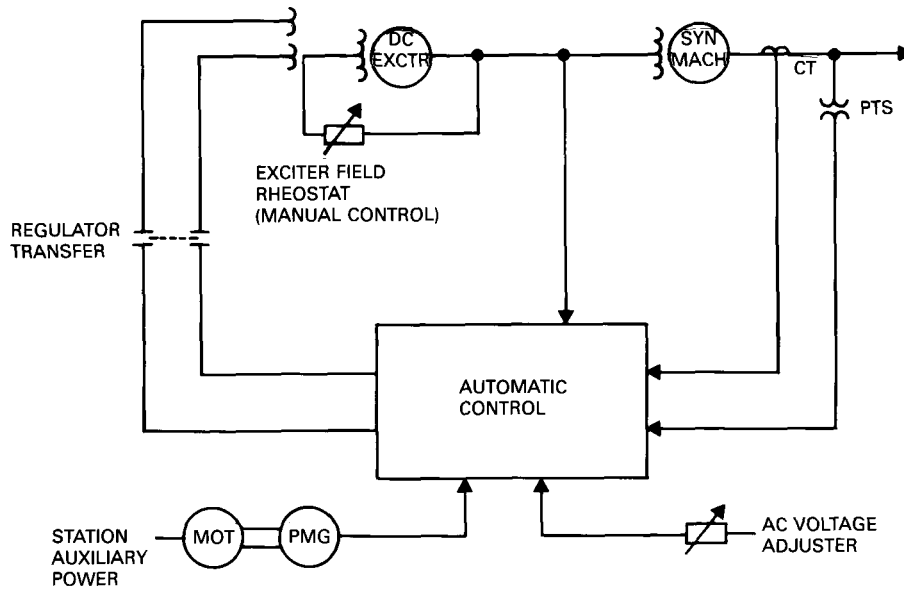
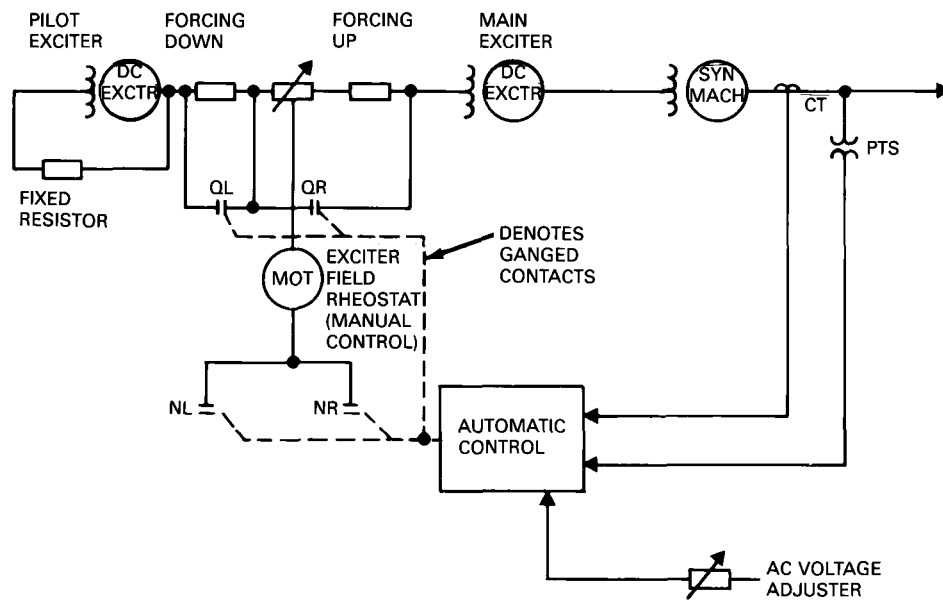

Figure 5—DC Generator-Commutator Exciter with Continuously Acting Regulator Employing Static Amplifiers



NOTES: (1) NL, NR — Close for small error
 QL, QR — Close for large error

Figure 6—DC Generator-Commutator Exciter Separately Excited with Noncontinuously Acting Rheostatic Regulator

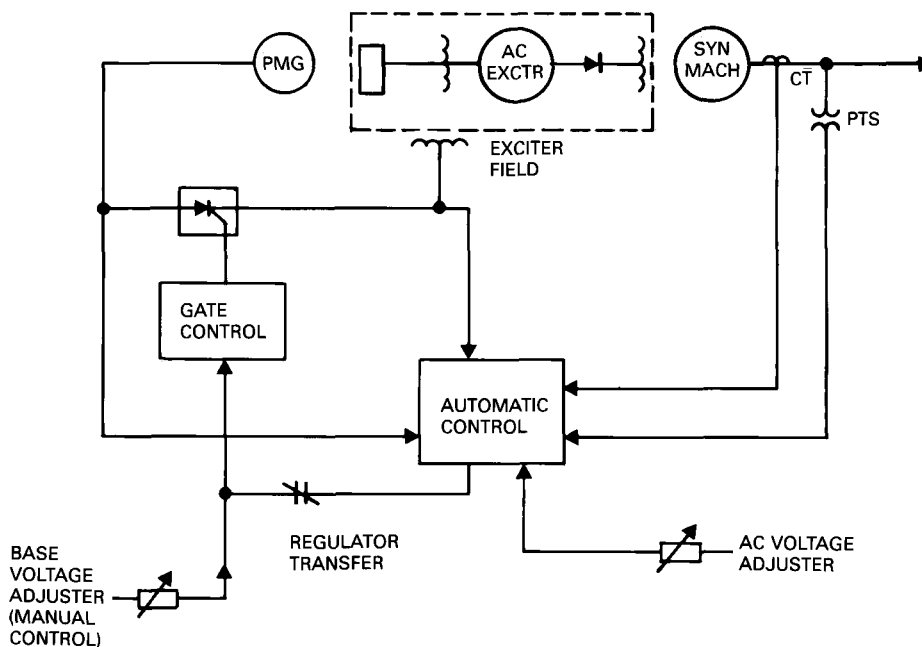

Figure 7—Alternator-Rectifier Exciter Employing Rotating Noncontrolled Rectifiers (Brushless)

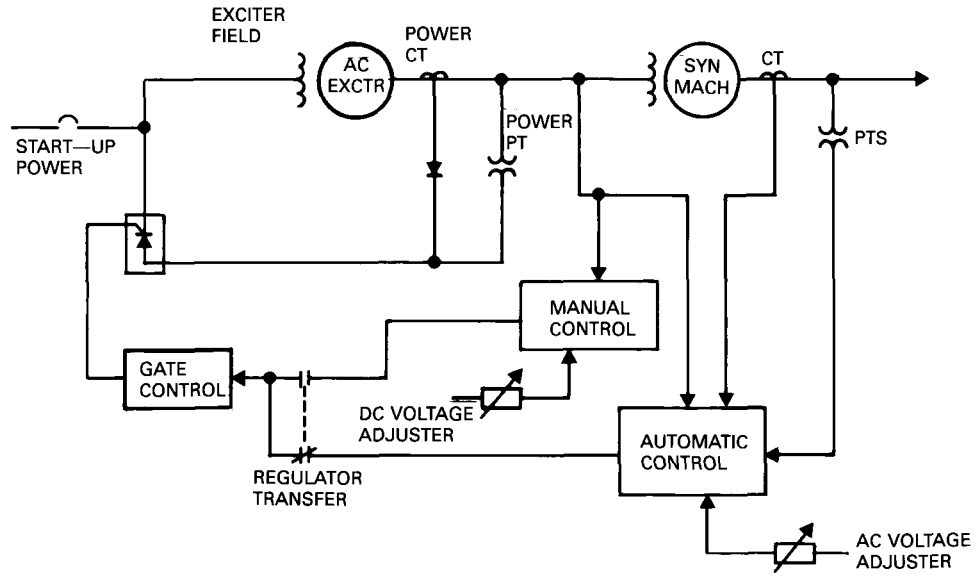

Figure 8—Alternator-Rectifier Exciter Employing Stationary Noncontrolled Rectifiers

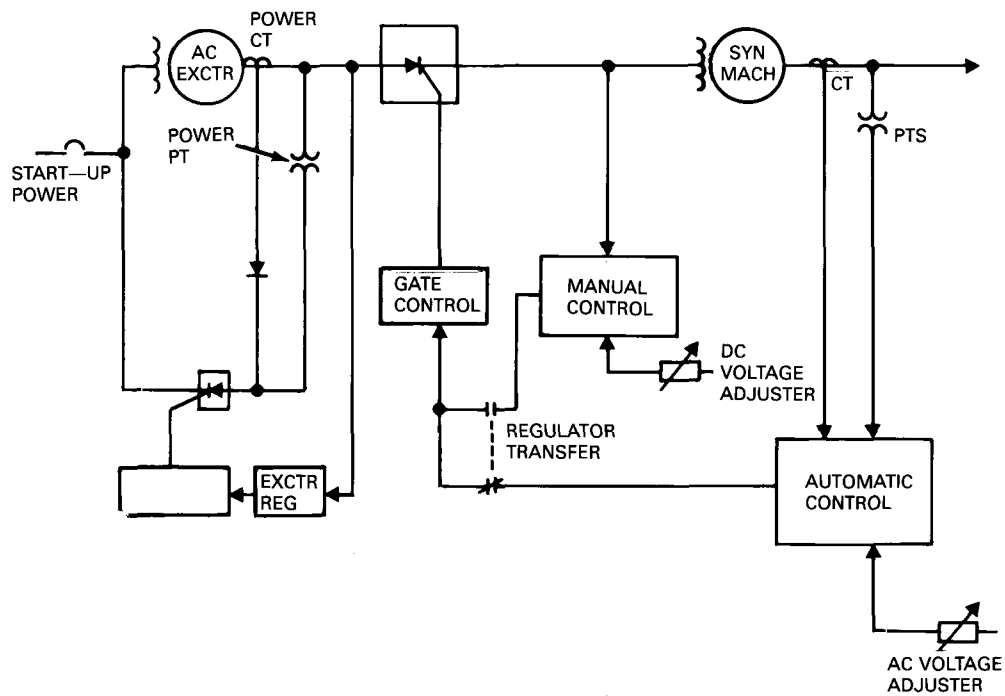

Figure 9—Alternator-Rectifier Exciter Employing Controlled Rectifiers

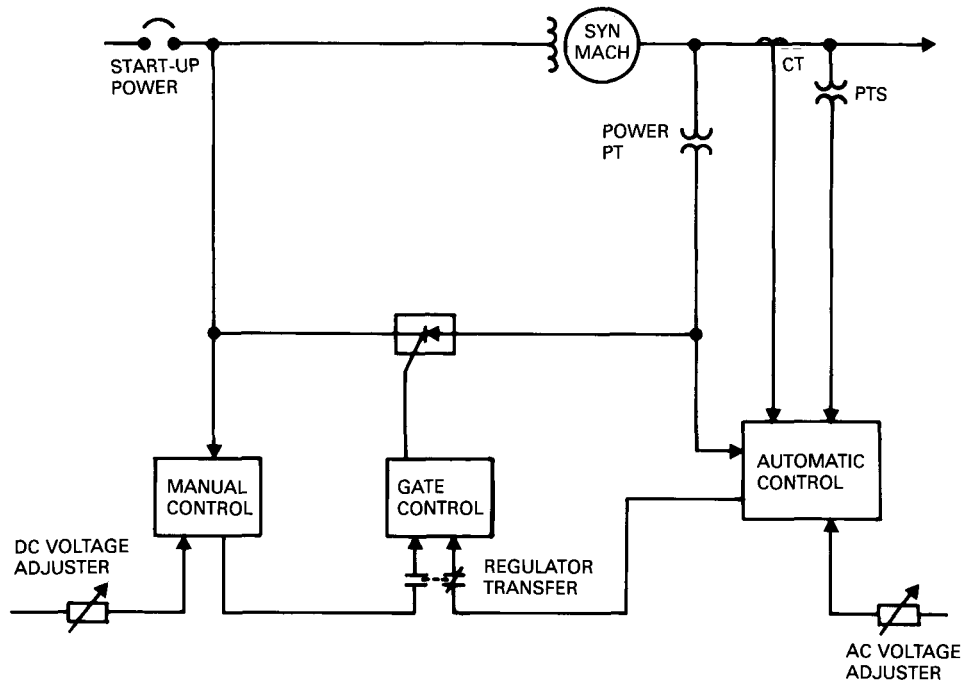

Figure 10—Potential Source-Rectifier Exciter Employing Controlled Rectifiers

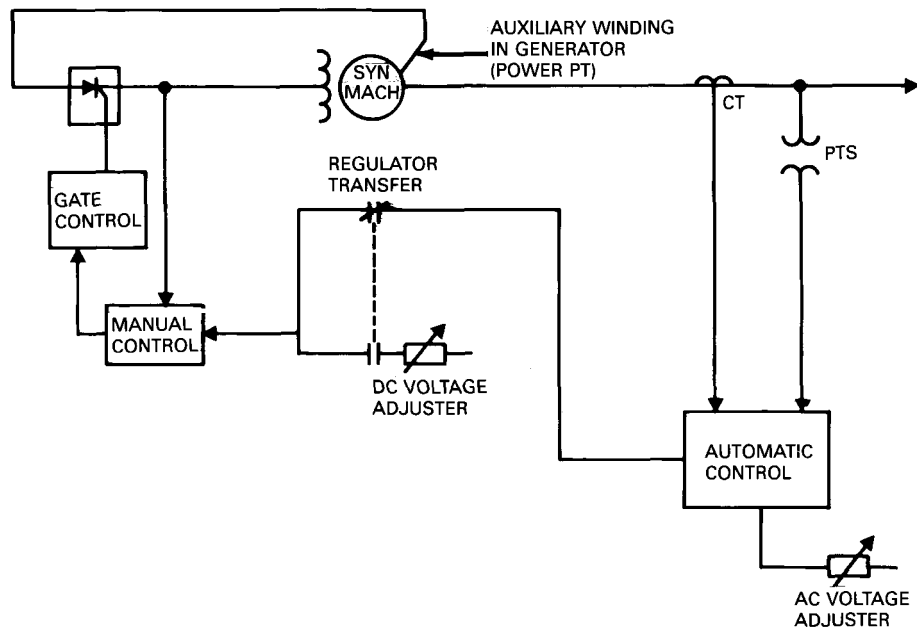

Figure 11—Potential Source-Rectifier Exciter Employing Controlled Rectifiers

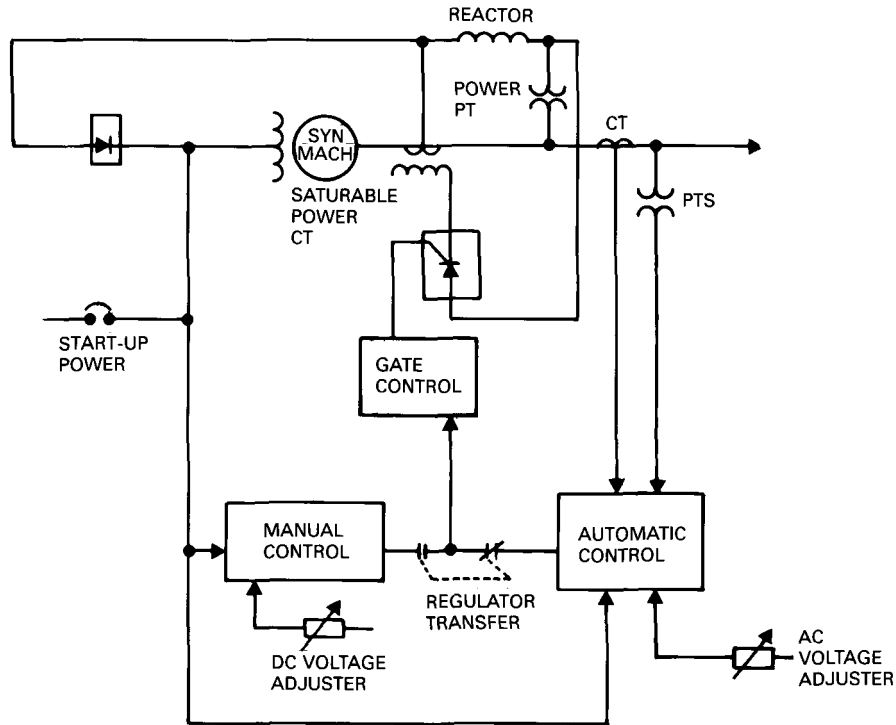

Figure 12—Compound Source-Rectifier Exciter Employing Noncontrolled Rectifiers

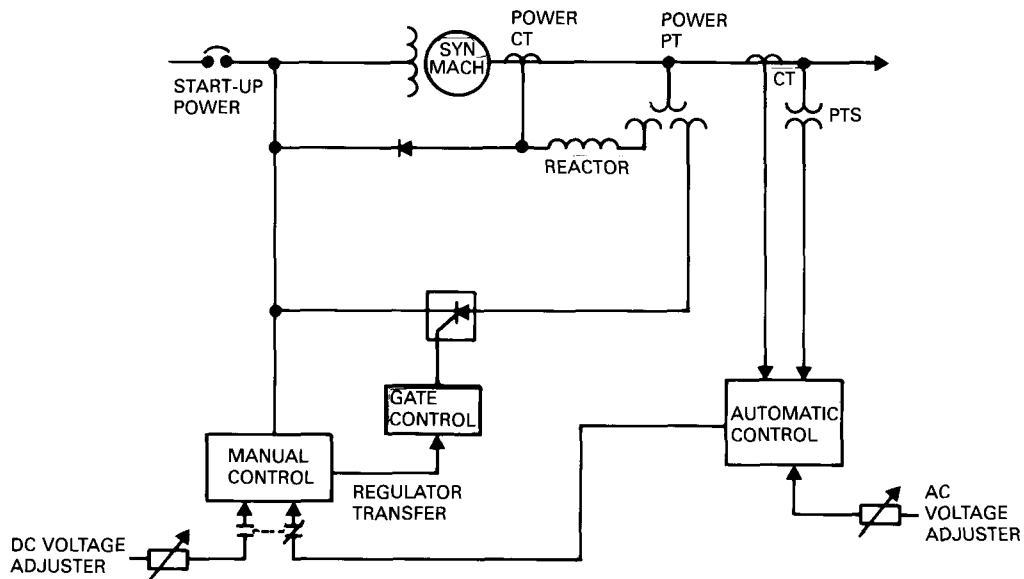

Figure 13—Compound Source-Rectifier Exciter Employing Controlled Rectifiers

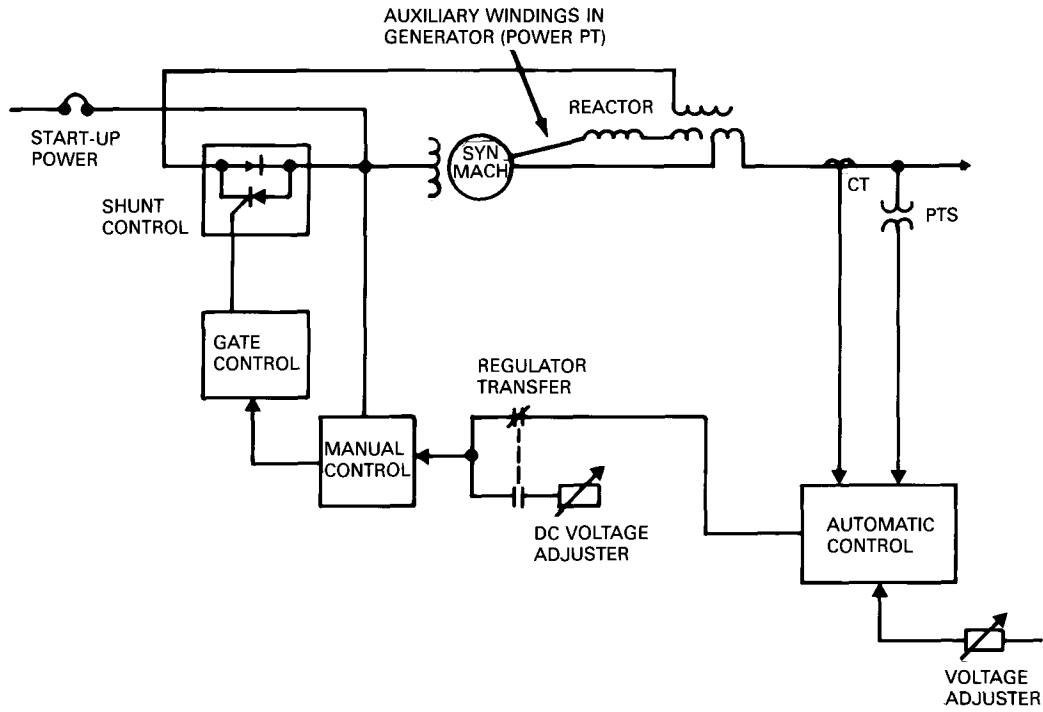

Figure 14—Compound Source-Rectifier Exciter Employing Shunt Controlled Rectifiers

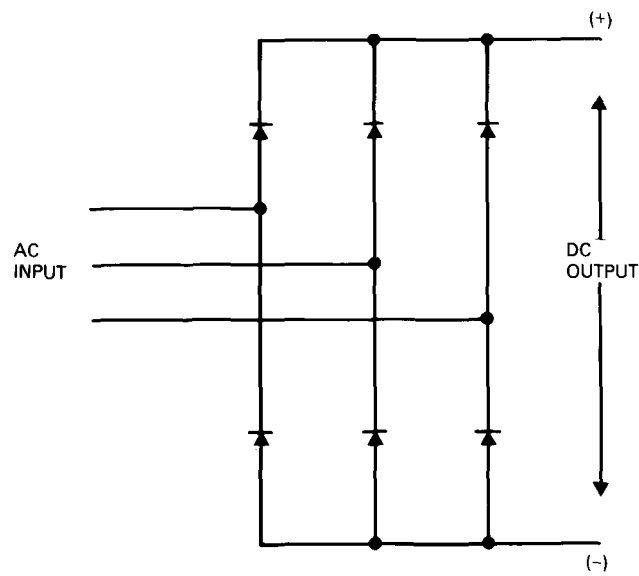

Figure 15A—Three-Phase Full-Wave Diode Bridge (Noncontrolled Rectifier)

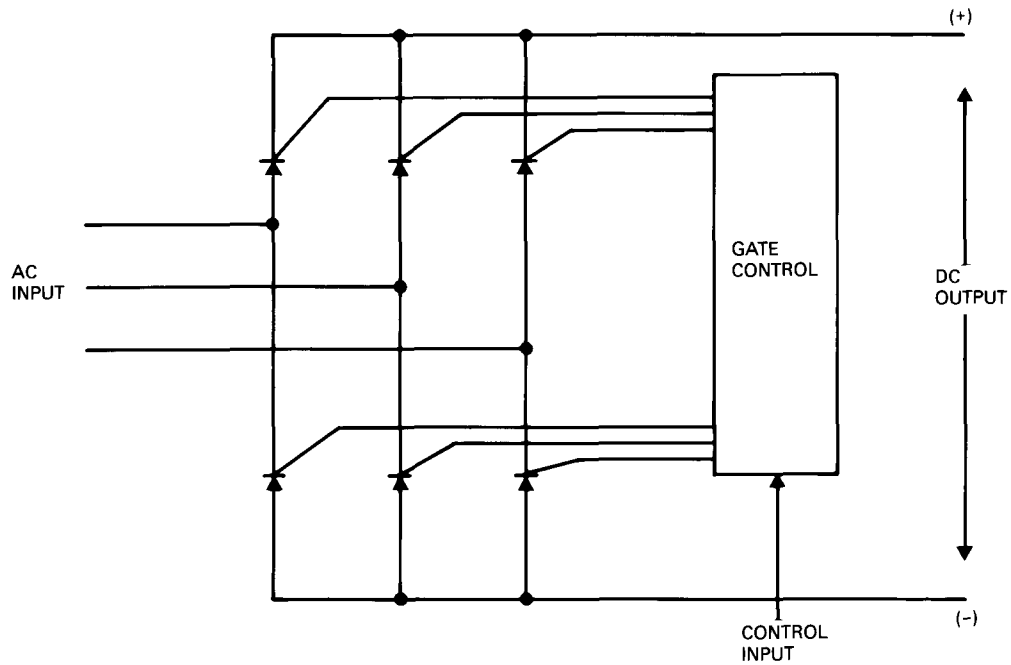

Figure 15B—Three-Phase Full-Wave Thyristor Bridge (Controlled Rectifier)

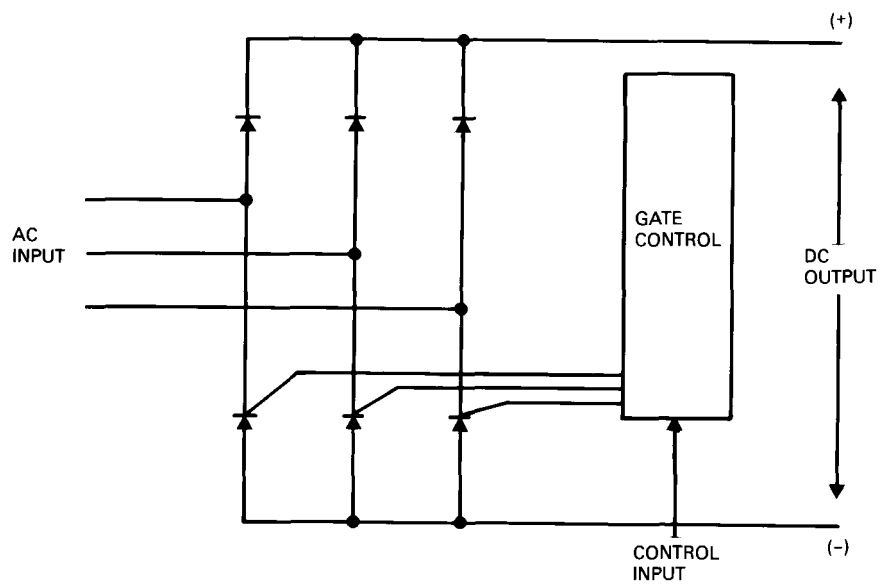

Figure 15C—Three-Phase Full-Wave Bridge with Diodes and Thyristors (Hybrid Controlled Rectifier)

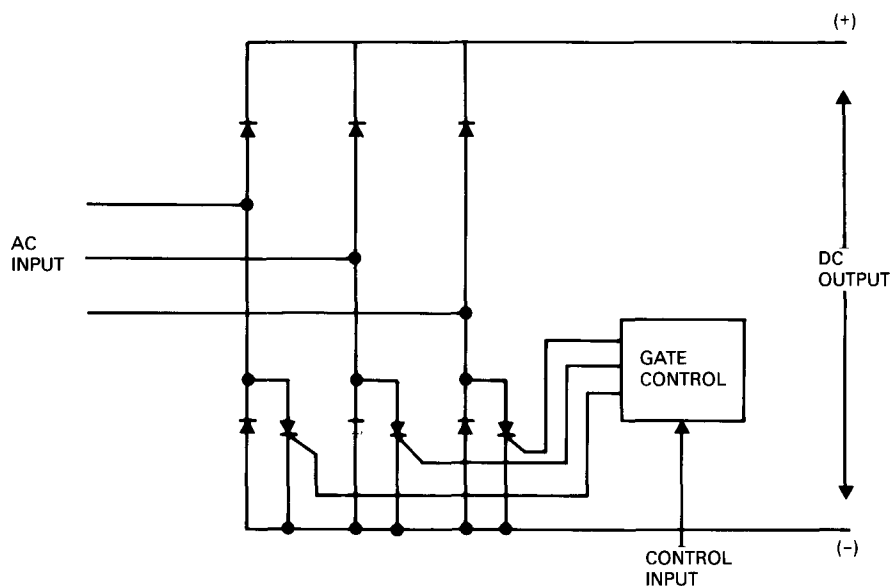

Figure 15D—Three-Phase Full-Wave Diode Bridge with Shunt Thyristors (Shunt Controlled Rectifier)

5. Bibliography

- [B1] IEEE Committee Report, Excitation System Models for Power System Stability Studies, *IEEE Transactions on Power Apparatus and System*, vol PAS-100, no 2, Feb 1981, pp 493–509.
- [B2] BARNES, H. C., OLIVER, J. A., RUBENSTEIN, A. S., and TEMOSHOK, M. Alternator-Rectifier Exciter for Cardinal Plant 724-MVA Generator. *IEEE Transactions on Power Apparatus and Systems*, vol PAS-87, Apr 1968, pp 1189–1198.
- [B3] CHAMBERS, G. S., RUBENSTEIN, A. S., and TEMOSHOK, M. Recent Developments in Amplidyne Regulator Excitation Systems for Large Generators. *AIEE Transactions (Power Apparatus and Systems)*, vol 80, 1961, pp 1066–1072.
- [B4] COTZAS, G. M., CRENSHAW, M. L., and RICHARDSON, G. L. GENERREX-PPS (Potential Power Source) Excitation System for Wisconsin Power and Light, Edgewater 5, *Proceedings of the Fourth-Third American Power Conference*, Apr 1981.
- [B5] COTZAS, G. M., DREXLER, K. F., DVORSCAK, J. J., and GERLITZ, R. L. Descriptions and Tests of the GENERREX Excitation System for Large Steam Turbine-Generators, *IEEE Transactions on Power Apparatus and Systems*, vol PAS-95, May/June 1976, pp 803–810.
- [B6] DILLMAN, T. L., KEAY, F. W., RACZKOWSKI, C., SKOOG LUND, J. W., and SOUTH, W. H. Brushless Excitation, *IEEE Spectrum*, March 1972, pp 58–66.
- [B7] DOMERATZKY, L. M., RUBENSTEIN, A. S., and TEMOSHOK, M. A Static Excitation System for Industrial and Utility Steam Turbine-Generators. *AIEE Transactions (Power Apparatus and Systems)*, vol 80, 1961, pp 1072–1077.
- [B8] KEAY, F.W., and SOUTH, W.H. A Solid-State Regulator for Electric Utility Applications, *IEEE Transactions on Power Apparatus and Systems*, vol PAS-90, no 4, July/Aug 1971, pp 1527–1547.

[B9] LANE, L. J., ROGERS, D. F., and VANCE, P. A. Design and Tests of a Static Excitation System for Industrial and Utility Steam Turbine-Generators. *AIEE Transactions (Power Apparatus and Systems)*, vol 80, 1961, pp 1077–1085.

[B10] LEE, C. H., and KEAY, F. W. A New Excitation System and a Method of Analyzing Voltage Response. *1964 IEEE International Convention Record*, vol 12, pt 3, pp 5–14.

[B11] McClymont, K. R., Manchur, G., Ross, R. J., and Wilson, R. J. Experience with High-Speed Rectifier Excitation Systems. *IEEE Transactions on Power Apparatus and Systems*, vol PAS-87, June 1968, pp 1464–1470.

[B12] Whitney, E. C., Hoover, D. B., and Bobo, P. O. An Electric Utility Brushless Excitation System. *AIEE Transactions (Power Apparatus and Systems)*, vol 78, 1959, pp 1821–1824.

[B13] Woolridge, P. A. B., and Blythe, A. L. Considerations Affecting the Design Philosophy of Solid-State Exciters. *IEEE Transactions of Power Apparatus and Systems*, vol PAS-87, May 1968, pp 1288–1299.